

Dome2-P/T

Dome2HR-P/T *HIGH RESOLUTION*

User's Manual

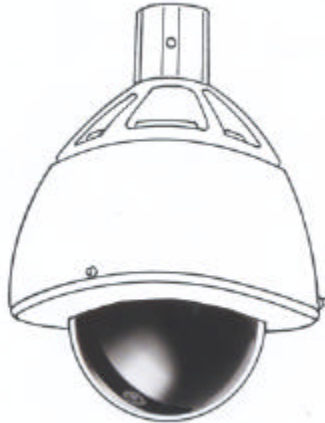

Before attempting to connect or operate this product, please read these instructions completely

Main Features

1 Built-in receiver

- Complete digital control with integrated CPU and SD RAM. All configurable options stored in non-volatile memory to protect against power cuts.
- Integration and high durability.
- 16 programmable presets.
- RS485 communication data, dome address 0-511.
- Support Auto tour and pattern.

2 Pan/tilt drive

- Innovative design of the structure minimizes the outline shape and dimensions.
- A precision drive positioning system ensures a 0~355°pan rotation.
- Tilt rotation range 0-90°.

3 Built-in color camera with high sensitivity and high resolution

- 3.6 mm lens fitted, other sizes available
- Auto back light compensation
- Auto white balance

Optional keyboard control



Preface

The 5” mini dome is an integration of the cutting-edge technique, most developed manufacturing process and years of full experience in the industry. Equipped with high-resolution camera and digital decoder, it represents the trend of the new edition of surveillance product. Being complete-digital-controlled and flexile programmable, it performs an excellent fast-location and continuous object tracing. The simple and compact structure ensures high reliability and long term running.

Super features lead a wide variety of use in large area surveying and moving object tracing. For instance, integration building and banks securing, traffic supervising, power stations watching, airports and stations monitoring. The protocol is open and the dome is compatible with the host of systems.

This manual introduces dome functions and operations. Please read this manual carefully prior to installation and operation.

Precautions

1 Transportation

Domes are sophisticated products and as such should be protected against extremes of pressure, temperature, vibration and humidity during storage and transportation.

2 Do not disassemble the Dome module

There are no user serviceable parts or settings inside. Failure to observe this instruction could result in damage to the product and loss of warranty. Only suitably qualified and authorized personnel may undertake repairs.

3 Installation

This Camera is suitable for use indoors or outdoors however before using outdoors please read the information under "Exposure" heading at:
<http://www.allthings.com.au/Appnotes>

4 Electrical safety

Conform to local Electrical safety codes when use this product, keep at least 50 meter between dome, communication data and high voltage equipment or cables.

If above requirements can not be satisfied, please use steel tube to shield communication Data cable, and make it grounding.

5 Cleaning

In order to get clear image, down cover should be cleaned periodically. Be careful when cleaning, only hold down cover edge , avoid direct touching down cover, acid matter in the fingers will corrupt down Cover plating surface. Hard material scratching down cover will lead to vague image. Please use soft clean cloth or other substitution to clean interior and exterior surface. Neutral detergent as well as any high-grade furniture detergent can be used to clean down cover.

6 Environment

The operation temperature of the dome is -30? ~50? , humidity is less than 90%, input power supply is AC24V. Do not use the dome in circumstances where temperature, humidity or power supply variations fall outside the range of specified values.

7 Excessive light

It is important that the dome camera is not left in a position where the camera is pointing directly at the sun or other extremely bright light source. This may result in CCD damage and poor image quality.

Functions and Operations

These operating instructions cover the basic operation of the dome and its features. When the dome is used with other manufacturers control system, please regard the system controller instruction as standard. In the event of special requirements outside the scope of this document it is advisable to contact your local distributor.

1. Setting the dome ID

Setting dome ID by the DIP Switch of the dome, refer to the dome setting for the details.(P.6)

2. Set up and call preset

Preset function is that dome stores current horizontal angle and title angle of pan/Tilt, and position parameters into the memorizer. When necessary dome calls these parameters and adjusts Pan/Tilt and camera to that position. Operator can store and call presets easily and promptly by using controller, the dome supports up to 64 presets.

- To set a preset position + +
- To call a preset position + +

3. Auto Cruise

The preset positions can be programmed to be re-called in a set of sequence. This sequence can be set to automatically cycle from one position to the next at a setting time. This feature is called Auto cruise.

- Cruise sequence can be programmed from 1~16 presets.
- Start Auto cruise : + +
- Stop Auto cruise by moving the joystick.

4. Auto Pan function

The auto pan function allows you to have the camera move back and forth automatically, at a preset speed between the 2 preset camera positions.

- START : AUTO + N1 + ON + N2 + OFF

N1 stands for the position you want to start

N2 stands for the position you want to stop

- STOP : AUTO + OFF

or Move joystick, the dome will be controlled by manual and the auto pan will stop.

Dome Setting

According to the different controlling system, confirm the used controlling system before operation setting

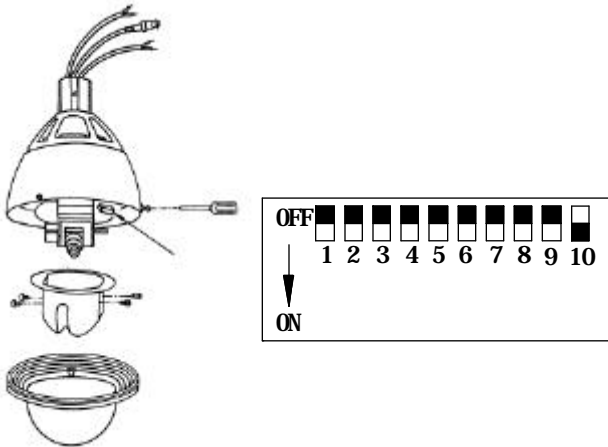

ID10 is for RS485 1200 impedance. When control distance is far or environment interference is severe, the ID10 should be set "ON", when the

system connects many domes, ID10 of the farrest dome from controller should be set “ON”, other domes are set “OFF”.

Address	Switch 9	Switch 8	Switch 7	Switch 6	Switch 5	Switch 4	Switch 3	Switch 2	Switch 1
1	OFF	OFF	OFF	OFF	OFF	OFF	OFF	OFF	ON
2	OFF	OFF	OFF	OFF	OFF	OFF	OFF	ON	OFF
3	OFF	OFF	OFF	OFF	OFF	OFF	OFF	ON	ON
4	OFF	OFF	OFF	OFF	OFF	OFF	ON	OFF	OFF
5	OFF	OFF	OFF	OFF	OFF	OFF	ON	OFF	ON
6	OFF	OFF	OFF	OFF	OFF	OFF	ON	ON	OFF
7	OFF	OFF	OFF	OFF	OFF	OFF	ON	ON	ON
8	OFF	OFF	OFF	OFF	OFF	ON	OFF	OFF	OFF
9	OFF	OFF	OFF	OFF	OFF	ON	OFF	OFF	ON
10	OFF	OFF	OFF	OFF	OFF	ON	OFF	ON	OFF
11	OFF	OFF	OFF	OFF	OFF	ON	OFF	ON	ON
12	OFF	OFF	OFF	OFF	OFF	ON	ON	OFF	OFF
13	OFF	OFF	OFF	OFF	OFF	ON	ON	OFF	ON
14	OFF	OFF	OFF	OFF	OFF	ON	ON	ON	OFF
15	OFF	OFF	OFF	OFF	OFF	ON	ON	ON	ON
16	OFF	OFF	OFF	OFF	ON	OFF	OFF	OFF	OFF
17	OFF	OFF	OFF	OFF	ON	OFF	OFF	OFF	ON
18	OFF	OFF	OFF	OFF	ON	OFF	OFF	ON	OFF
19	OFF	OFF	OFF	OFF	ON	OFF	OFF	ON	ON
20	OFF	OFF	OFF	OFF	ON	OFF	ON	OFF	OFF
...	
510	ON	ON	ON	ON	ON	ON	ON	ON	OFF
511	ON	ON	ON	ON	ON	ON	ON	ON	ON

When there is more than one dome adopted in the system, connect the controlling cable in parallel, set the dome address by setting ID Switcher, control the domes connected with one keyboard controller. Refer to the controlling system manual for the detailed connection and operation.

Installation

Prior to installation and use of this product, the following warnings should be observed:

1. Installation and servicing should only be done by qualified service personnel or system installation personnel and conform to all local codes.
2. When unpacking dome package, Pan/Tilt module should be handled with care, not use hard thing to hit camera and other parts to avoid unnecessary trouble.
3. Domes installation position must be away from high voltage as far as possible.
4. Setting the dome address, controlling mode and protocol appropriately before installation.

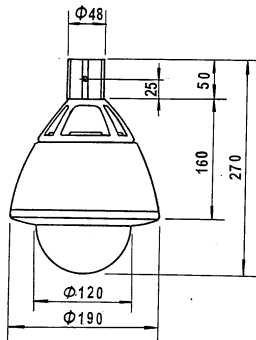

Wall Bracket (Optional)

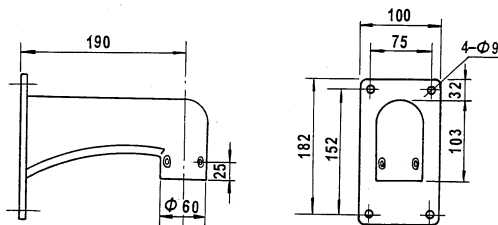

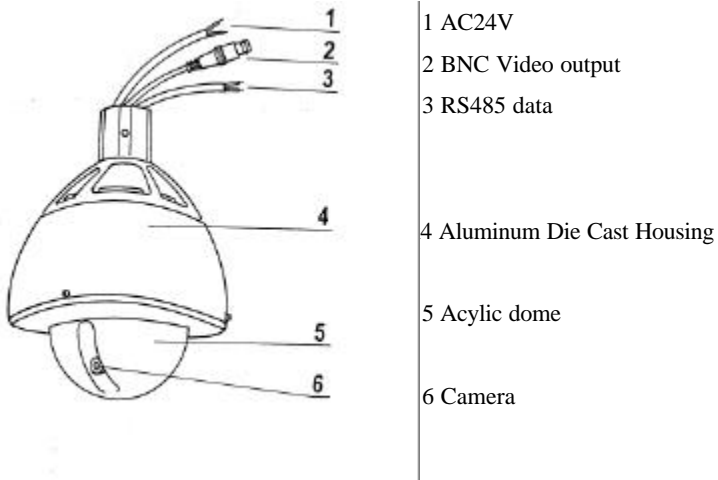

Dome Connection Diagram

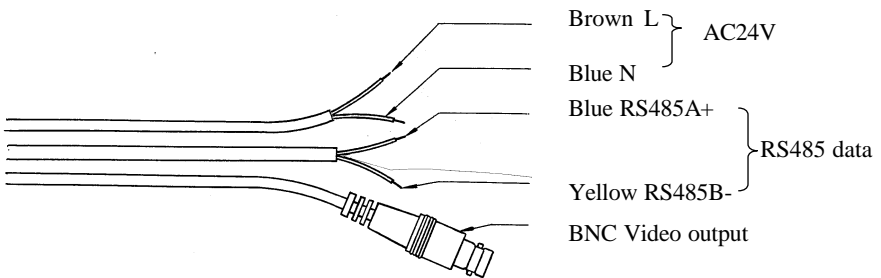

Dome Structure Diagram

1. Connection Instruction

- 1) Video output connects to matrix or monitor
- 2) RS485 controlling cable: Blue cable connects to RS485A+; Yellow cable connects to RS485B-

2. Dome Installation

- 1) Installing speed dome camera to the bracket using 4-M6 Screws.
- 2) Installing the bracket to an existing structure.

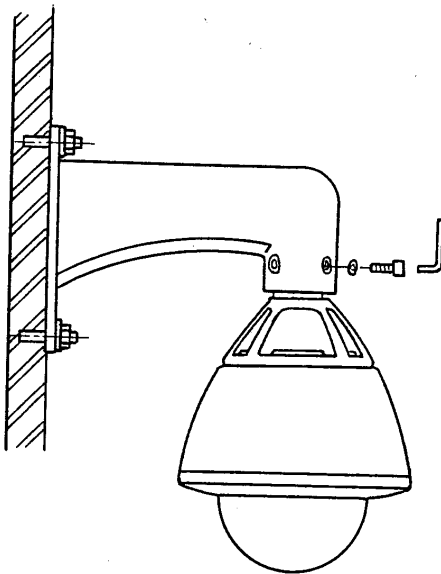

Trouble Shooting Table

Problem	Probable causes	Solution
On Power no action no image	Power supply plug-in loose	Plug tightly
	Fuse on the power PCB damaged	Replace
On Power, self check and image ok, can not control	Protocol setting is wrong	Check the keyboard
	Dome ID setting is wrong	Change the dome ID
	RS-485 Bus bad connection	Check RS-485 connection
Vague Image	Lens loose	Adjust the lens again
	Down cover not clean	Clean down cover

Intelligence Dome Camera Control Command Reference

? Camera Interface: RS-485

·Transmit Method : Asynchronous Interface Half Duplex Serial Communication

·Transmit Speed : 9600bps

·Protocol : 1 Stop bit ; 8-bit data; No Parity; 1 Stop bit

2. Command Protocol

Command length is fixed at 11 bytes (1 packed). The packet's data arrangement is as follow Below.

WORD1	STX (Start of Text)	A0H
WORD2	Receiver Address	00H~ 1FH
WORD3	Sender Address	00H~ 1FH
WORD4	COMMAND(1)	
WORD5	COMMAND(2)	
WORD6	DATA(1)	
WORD7	DATA(2)	
WORD8	DATA(3)	
WORD9	DATA(4)	
WORD10	ETX (End of Text)	AFH
WORD11	Check-Sum	

Calculation of the Check-Sum

- Sum up WORD2 through WORD9
- Deduct the above total from the FFFFH
- Last two digits are the Check-Sum
- For example: In case the total of WORD2 through WORD9 is 567H, A00H
FFFFH-567H=A98H? Check-Sum = 98H
FFFFH-A00H=5FFH? Check-Sum = FFH

3. Command Details

Commands are of two types: PTZ commands and “extended” commands. The PTZ commands (see 3.1 below) specify manual operations, while the extended commands (see 3.2 below) implement camera settings. The command type is identified by Bit 0 of WORD5 —a “0” denotes a PTZ command, while a “1” denotes an extended command.

3.1. PTZ Command (Pan/Tilt/Zoom)

The PTZ command control general manual operations (PAN, TILT, ZOOM, FOCUS, IRIS). The PTZ commands take precedence over all extended commands other than the “special” extended command. The camera can be stopped by setting all bits of WORD4, WORD5 to “0”

The contents which each word shows when Bit0 of WORD5 is “0” as follow:

WORD4 (Command1)	-Bit7(MSB)	constant	0
	-Bit6	Not Used	0
	-Bit5	Not Used	0
	-Bit4	IRIS OPEN	00: IRIS STOP 01: IRIS CLOSE
	-Bit3	IRIS CLOSE	10: IRIS OPEN 11: Keep the current movement
	-Bit2	constant	0
	-Bit1	FOCUS NEAR	00: FOCUS STOP 01: FOCUS CLOSE
	-Bit0(LSB)	FOCUS FAR	10: FOCUS OPEN 11: Keep the current movement
WORD5 (Command2)	-Bit7(MSB)	constant	0
	-Bit6	ZOOM WIDE	00: ZOOM STOP 01: ZOOM TELE
	-Bit5	ZOOM TELE	10: ZOOM WIDE 11: Keep the current movement
	-Bit4	TILT DOWN	00: TILT STOP 01: TILT UP
	-Bit3	TILT UP	10: TILT DOWN 11: Keep the current movement
	-Bit2	PAN LEFT	00: PAN STOP 01: PAN RIGHT
	-Bit1	PAN RIGHT	10: PAN LEFT 11: Keep the current movement
	-Bit0(LSB)	PTZ command(0) / Extension Command(1)	
WORD6 (DATA(1))	PAN MOTOR SPEED (01H~ 40H)		
WORD7 (DATA(2))	TILT MOTOR SPEED (01H~ 40H)		
WORD8 (DATA(3))	Upper 4 Bits	Focus Motor speed(01H~ 08H)	
	Lower 4 Bits	Zoom Motor speed(01H~ 08H)	

WORD9 DATA9 (4)	FFH
--------------------	-----

There is a bit that controls four motors' rotating direction of PAN/TILT/ZOOM/FOCUS. When the bit is "1", it means that it is effective and it functions. However, when two of the bit that controls the opposite rotating direction are both "1", it means the current action is selected and is to be continued. When two of the bit that controls the opposite rotating direction are both "0", it means the motor to be stopped.

3.2. Extension command

These commands are used to implement non-manual settings---mainly Preset, Swing, Sequence, etc.

WORD4	00H
WORD5	Command No.01H to FFH (Only Odd Number)
WORD6 (DATA(1))	Parameter1
WORD7 (DATA(2))	Parameter2
WORD8 (DATA(3))	Parameter3
WORD9 DATA (4)	Parameter4

(1) Set Preset

WORD4	WORD5	WORD6	WORD7	WORD8	WORD9
00H	03H	XX	FFH	FFH	FFH

XX=00H~ 3FH(Preset Number)

(2) Go to Preset

WORD4	WORD5	WORD6	WORD7	WORD8	WORD9
00H	07H	XX	FFH	FFH	FFH

XX=00H~ 3FH(Preset Number)

(3) Run Pan Swing (1)

WORD4	WORD5	WORD6	WORD7	WORD8	WORD9
00H	11H	00H	P1	P2	FFH

P1=00H to 3FH Preset Number (First Specify Position)

P2=00H to 3FH Preset Number (Second Specify Position)

(4) Stop Swing

WORD4	WORD5	WORD6	WORD7	WORD8	WORD9
00H	1FH	FFH	FFH	FFH	FFH

(5) Run Sequence

WORD4	WORD5	WORD6	WORD7	WORD8	WORD9
00H	21H	GG	00H	FFH	FFH

<GG>: Sequence Number 00H~05H

Technical Data

Panning range	0 ~ 355°
Pan speed	0.45 ~ 45°/sec
Tilt range	0 ~ 90°
Tilt speed	0.45 ~ 45°/sec
Communication	RS485
Controls	Pan / Tilt; 16 preset positions
Auto pan	ON / OFF
Auto Tracking mode	ON / OFF; 1 cruising tracks
Power source	24 volts ac
Operating temperature	-30 ~ 50°
Weight	Approx 3.6 kg

The specification is subjected to change without notice

Multi-protocol Operation

1. ID Setting

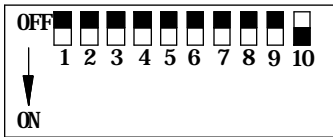

ADD	NO.6	NO.5	NO.4	NO.3	NO.2	NO.1
0	OFF	OFF	OFF	OFF	OFF	OFF
1	OFF	OFF	OFF	OFF	OFF	ON
2	OFF	OFF	OFF	OFF	ON	OFF
...
63	ON	ON	ON	ON	ON	ON

2. Protocol Setting

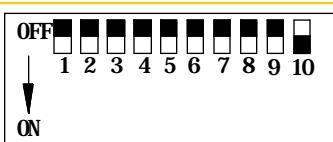

Protocol	NO.9	NO.8	NO.7
COP_02	OFF	OFF	OFF
COP_01	OFF	OFF	ON
PELCO-P 9600	OFF	ON	OFF
PELCO-P 4800	OFF	ON	ON

PELCO-D	ON	OFF	OFF
---------	----	-----	-----

3. Operation of auto panning and auto tracking

Operation	Function
<input type="text" value="PRESET"/> + <input type="text" value="17"/> + <input type="text" value="ENTER"/>	To preset NO.17 preset position means to set the start position of auto pan.
<input type="text" value="PRESET"/> + <input type="text" value="18"/> + <input type="text" value="ENTER"/>	To preset NO.18 preset position means to set the end position of auto pan.
<input type="text" value="CALL"/> + <input type="text" value="17"/> + <input type="text" value="ENTER"/>	To call the NO.17 preset position means to turn on auto tracking.
<input type="text" value="CALL"/> + <input type="text" value="18"/> + <input type="text" value="ENTER"/>	To call the NO.18 preset position means to turn on auto panning.
<input type="text" value="CALL"/> + <input type="text" value="19"/> + <input type="text" value="ENTER"/>	To call the NO.19 preset position means to stop auto panning.
* <input type="text" value="PRESET"/> + <input type="text" value="20"/> + <input type="text" value="ENTER"/>	To preset NO.20 preset position means to close the digital zoom.
* <input type="text" value="CALL"/> + <input type="text" value="20"/> + <input type="text" value="ENTER"/>	To call the NO.20 preset position means to open the digital zoom.

Auto Tracking: The Mini P/T Dome can automatically track from 1,2,3.....16 preset position. Dwell time between 2 preset position is 4 secs.

Auto Panning: The auto pan function allows you to have the Mini P/T Dome move back and forth automatically, at a preset speed between the 2 preset positions. The dwell time between the start preset position and the end preset position is 3 seconds.

* **Option.**